

**GRÉGOIRE**  **BESSON**

# SUBSOILER

**Hydraulic auto reset subsoiler  
For deep tillage**

## **OPERATOR'S MANUAL MAINTENANCE INSTRUCTIONS**



**GRÉGOIRE-BESSON S.A.**  
Rue Victor Grégoire  
49 230 MONTFAUCON – MONTIGNÉ  
France

Phone : 33 (0) 2 41 64 72 67  
Fax : 33 (0) 2 41 64 67 73

Web : [www.gregoire-besson.com](http://www.gregoire-besson.com)  
Email : [Contactfr@gregoirebesson.com](mailto:Contactfr@gregoirebesson.com)

Original version  
November 2009

# TABLE OF CONTENTS

|   |    |
|---|----|
| <b>1. INTRODUCTION</b> .....  | 4  |
| PRODUCT IDENTIFICATION .....  | 4  |
| <b>2. SAFETY INSTRUCTIONS</b> .....                                   | 5  |
| 2.1. SAFETY STICKERS .....  | 5  |
| 2.2. SAFETY WHILE ATTACHING AND DETACHING .....                       | 7  |
| 2.3. SAFETY WHILE CONNECTING HYDRAULIC LINES .....                    | 7  |
| 2.4. SAFETY WHILE OPERATING MACHINE .....                             | 7  |
| 2.5. SAFETY FOR MAINTENANCE .....                                     | 8  |
| 2.6. SAFETY FOR ON HIGHWAY TRANSPORT .....                            | 8  |
| <b>3. MACHINE DESCRIPTION</b> .....                                   | 9  |
| 3.1. IDENTIFICATION VIEWS .....                                       | 9  |
| 3.2. TECHNICAL SPECIFICATIONS .....                                   | 10 |
| 3.3. DIMENSIONS AND WEIGHTS .....                                     | 10 |
| 3.4. LIGHTS AND SIGNS KITS .....                                      | 10 |
| <b>4. PREPARING THE TRACTOR</b> .....                                 | 11 |
| 4.1. TRACTOR WHEELS .....   | 11 |
| <u>4.1.1. Tractor tyre</u> .....                                      | 11 |
| <u>4.2.2. Distance between tractor tyres</u> .....                    | 11 |
| 4.2. FRONT END WEIGHTING .....  | 11 |
| 4.3. POSITIONING STABILIZERS .....                                    | 12 |
| 4.4. LIFT LINKS LENGTH .....  | 12 |
| 4.5. TOP LINK .....   | 12 |
| <b>5. ATTACHING AND DETACHING</b> .....                               | 13 |
| 5.1. ATTACHING MACHINE TO TRACTOR .....                               | 13 |
| <u>5.1.1. Tractor equipped with tie rods lower links</u> .....        | 13 |
| <u>5.1.2. Tractor equipped with automatic hooks lower links</u> ..... | 13 |
| <u>5.1.3. Hitching top link</u> .....                                 | 14 |
| 5.2. DETACHING THE MACHINE .....                                      | 14 |
| <b>6. HYDRAULIC CONNEXIONS</b> .....                                  | 15 |
| 6.1. REQUIRED HYDRAULIC REMOTES .....                                 | 15 |
| 6.2. HYDRAULIC CONNECTIONS .....                                      | 15 |
| 6.3. HYDRAULIC PRESSURE IN NON-STOP SAFETY DEVICE .....               | 15 |
| <b>7. TRANSPORTING</b> .....  | 16 |
| 7.1. CHANGING TO TRANSPORT POSITION .....                             | 16 |
| 7.2. DRIVING ON PUBLIC ROAD .....                                     | 16 |
| <b>8. FIELD ADJSUTMENT</b> .....                                      | 17 |
| 8.1. FIELD UTILIZATION .....  | 17 |
| 8.2. ADJUSTING THE MACHINE .....                                      | 17 |
| <u>8.2.1. Depth control and front to rear levelling</u> .....         | 17 |
| <u>8.2.2. Side to side levelling</u> .....                            | 17 |

**9. MAINTENANCE** ..... 18

9.1. GENERAL INSTRUCTIONS ..... 18

9.2. LUBRICATION ..... 18

9.3. SPARE PARTS ..... 19

9.4. STORAGE SAFETY ..... 19

**QUICKLY STARTING - SUBSOILER** ..... 20

Any use and / or reproduction of all or part of this manual without written authorization from Grégoire-Besson is strictly prohibited.

# NOTES

# 1. INTRODUCTION



## **READ CAREFULLY THIS MANUAL**



To properly start, operate and service your equipment, follow all instructions given in this manual.

**THIS MANUAL SHOULD BE CONSIDERED AS A PART OF THE EQUIPMENT AND SHOULD FOLLOW IT WHEN YOU SELL IT.**

**LEFT HAND SIDE AND RIGHT HAND SIDE, FRONT AND REAR** are determined looking from equipment towards tractor when in work.

**ALL INFORMATIONS, PICTURE, SPECIFICATIONS** in this manual are based on the newer information available at the time of publication. Pictures and drawings might not represent standard equipment and show optional attachments.

Manufacturer reserves right to make any changes at all time **without any obligation to notice or to modify any delivered or already sold machine.**

**If the machine has been modified in any way from the original design without written agreement from Grégoire-Besson, the manufacturer does not accept any liability for injury or warranty. Warranty would become void.**



This symbol is used in the following manual to **catch your attention on warnings concerning your safety.**

So please when you see it in this manual or on the equipment, **strictly follow given information.**

Grégoire-Besson equipments are exclusively designed to be used by professionals for regular farm tillage in farmed fields. Manufacturer shall not be responsible for damage or injury resulting from any other use.

Grégoire Besson equipments are designed according to applicable european regulation : EEC directive 2006/42. The CE logo is on identification plate. Provided Declaration of Conformity testifies that machine complies with essential health and safety requirements for users.

## PRODUCT IDENTIFICATION

Please record here purchasing date, model and serial number of your equipment (refer to identification plate on hitch). Always refer to these information to get prompt and good service. Fill and send back machine registration form for warranty.

Purchasing date : .....

Model : .....

Serial number : .....

Salesman's phone : .....

## 2. SAFETY INSTRUCTIONS

### 2.1. SAFETY STICKERS

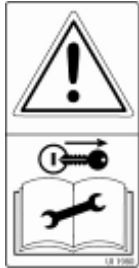

Reference : UI 1980

#### READ OPERATOR'S MANUAL

Read operator 's manual and safety instructions before starting the use of your equipment and follow them while using.



Reference : UI 1978

#### STAY IN A SAFE POSITION

Do not climb on the machine. Do not strand between machine and tractor.



Reference : UI 127

#### MOVE AWAY FROM THE MACHINE

Danger in the working area, stay clear from the machine.



Reference : UI 126

#### UNFOLDING AREA

Stay clear of equipment when folding or unfolding.



Reference : UI 131

#### SECURE THE MACHINE BEFORE ACTION

Always install all lockup devices to secure machine before any intervention on it.



Reference : UI 1979

#### MOVING PARTS

Always stay far away from parts in movement.



Reference : UI 128

#### HYDRAULIC LEAK AND MAINTENANCE

Caution, high pressure fluids can cause injury. Follow safe practices.



Reference : UI 1981

#### MACHINE UNFOLDING

Never stand under machine lateral sections.  
Always store machine unfolded.

### Positioning safety stickers on the machine

When cleaning the machine, do not damage stickers.  
Replace any damaged or missing sticker.

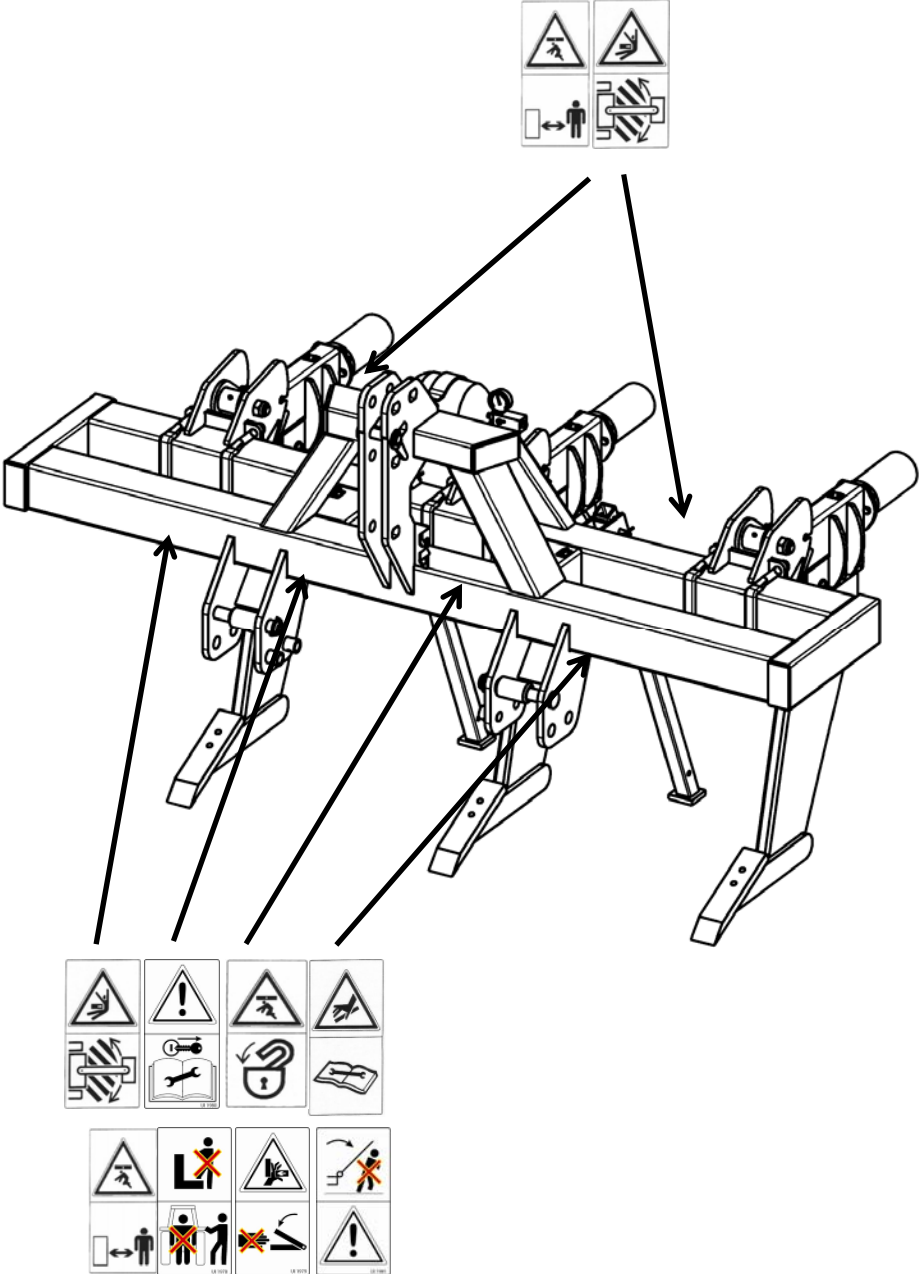

## 2.2. SAFETY WHILE ATTACHING AND DETACHING



- Do not let **anyone to stand between the machine and the tractor** when you back up to hitch.
- Before leaving the tractor to hitch or unhitch, set tractor parking brakes.
- Never attempt to attach the machine if pins, tractor hitching balls, tractor drawbar, or machine linkage are worn, cracked or not compatible.
- Completely lower the machine to the ground before unhitching. Make sure it is on a level and firm surface.
- Remove pressure from hydraulic lines before disconnecting them.
- Before leaving the machine for storage, make sure it is in a safe place and that there is no risk to damage whether anything or anyone.

## 2.3. SAFETY WHILE CONNECTING HYDRAULIC LINES



- Hydraulic circuit might be highly pressurised.
- **Never use your hands to locate a hydraulic leak.** Hydraulic fluids escaping under pressure have sufficient force to penetrate the skin, causing severe injury. In case of any injury, **see a doctor immediately.**
- For equipments loaded with several hydraulic connectors, **make logical and appropriated connections.**
- Before connecting hydraulic circuit, **make sure that there is no pressure on both sides (tractor and machine).**
- Regularly check hydraulic lines and connections. **Replace any damaged or leaking component** by an original part with the same specifications.
- Before any intervention on hydraulic circuit, **lower machine to the ground and release pressure moving control lever in the tractor's cab.**

## 2.4. SAFETY WHILE OPERATING MACHINE

- **Never attempt** any intervention on the machine while it is in motion.
- Do **not** allow anyone to **stand close to pivot points** : bottoms safety device (shearing bolt or non-stop), all pivoting linkage.
- Wear close **fitting clothing** and **appropriate safety devices** for the job you have to do (heavy leather gloves, safety shoes, earplugs, ... ).
- Do not allow anyone to stand close to the machine.
- Do not attempt to do any adjustment if you have not perfectly understood its procedure.
- Always use tools or equipments appropriate to the job you are doing. All Grégoire-Besson equipments are metric standards.
- Learn how to operate your machine and how to use its controls. Do not let anyone operate without instruction.
- Do not extend turnbuckle adjusters too much to avoid any threads damaging or intempesive pulling out.
- Only one person (the operator) should be in the tractor's cab when it is in operation. **No one on the machine while working or travelling on the road.**
- When earring or feeling unusual vibrations, stop the machine. Find the problem and solve it before starting operating again.



If your machine is equipped with a hydraulic folding mechanism, **always use it from tractor's cab**, once you are sure that folding area is free from spectators or obstacles.



## 2.5. SAFETY FOR MAINTENANCE



- Maintenance area shall be **clean, dry, with enough light and ventilation**.
- For any intervention on the machine in raised position, **always securely support all components** before starting maintenance.
- **Maintenance operations on elements under pressure or under tension** (resorts, accumulators, ...) require specific procedure and equipments. **Only qualified persons shall perform them in appropriate conditions**.
- After servicing remove all tools, components and parts you used.
- Regularly **check tightness of wheel studs, wearing parts bolts, and all other bolts and nuts**.
- **Always use genuine parts corresponding to manufacturer's technical specification requirements**.

## 2.6. SAFETY FOR ON HIGHWAY TRANSPORT



FOR YOUR OWN SAFETY AND THE ONE OF THE OTHER, RESPECT THE FOLLOWING RULES :

- All Grégoire-Besson equipments shall be used **complying with area's current rules and laws** concerning **safety instructions, accident prevention and provision of Highway Code**.
- Before road transport, always **check for wheels studs** and wheels mounting brackets carriage bolts **tightness** ; **check tyres general state and pressure** : do not drive with low pressure, cuts or damaged tyres or rims.
- **Use all devices required by your area's current laws** (lights, reflectors, signs, ... ). They might be removed during field operation to prevent from any damage. It is the operator's responsibility to comply with current law and to follow its evolutions.
- Regularly check hitching pins, change them if necessary. Tractor's ball joint may also wear, do not hesitate to replace them with new ones having at least Waltersheid fabrication quality.
- Drive **at reasonable speed** complying with local laws **to always keep control** of tractor and equipment. Pay special attention on irregular or rough roads. **Do not attempt to drive down a hill faster than it could be possible to drive it up**.
- Tractor used for road transport shall have the same power rating and weight as the one used for field operations.
- **Never attempt any manoeuvre if area is not free from spectators**.
- If your machine is equipped with a **folding mechanism** (manual or hydraulic), **use it making sure folding area is free from spectators** and obstacles.
- Follow all **safe driving practices** when travelling, moreover **on corners, rough or narrow roads**.
- When **leaving tractor** even for a short period, **shut off engine, remove ignition key and set parking brakes**.
- Forbid anyone to stand between tractor and machine or on the machine travelling on the road.

### 3. MACHINE DESCRIPTION

#### 3.1. IDENTIFICATION VIEWS

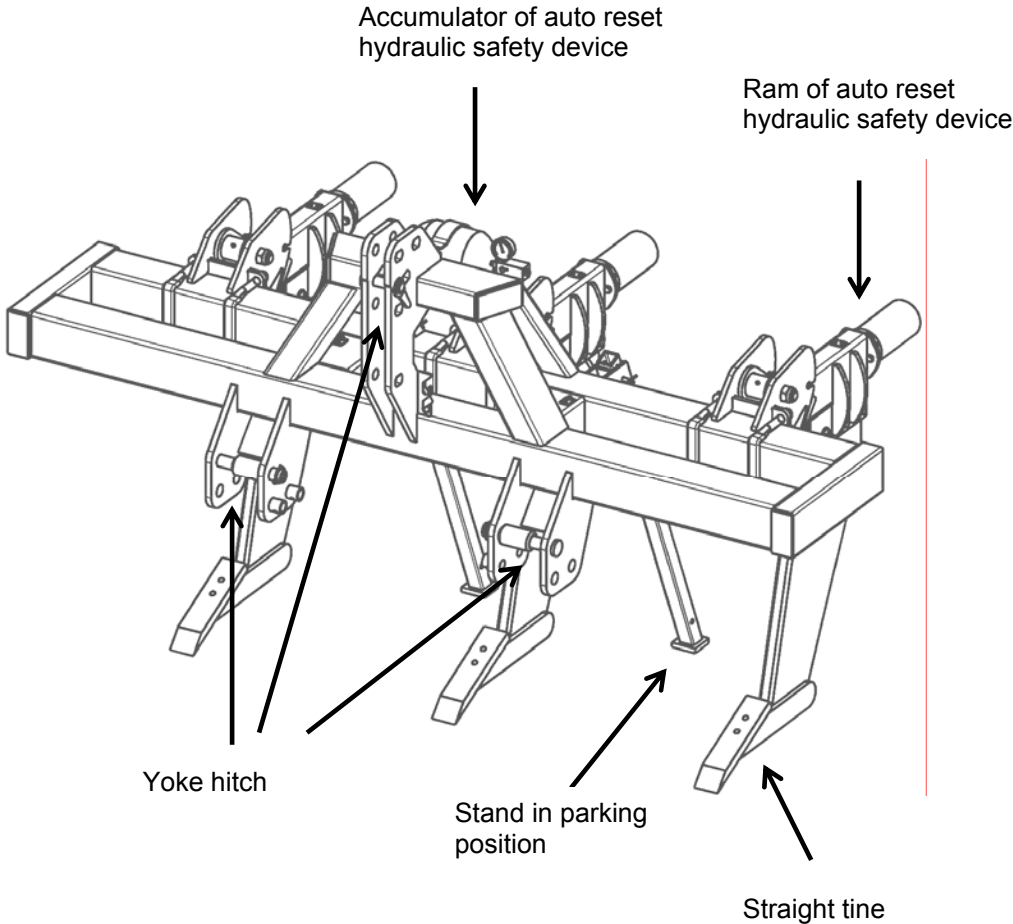

## 3.2. TECHNICAL SPECIFICATIONS

| Specification | Standard equipments   |
|---------------|---|
| Hitch         | <ul style="list-style-type: none"> <li>Yoke hitch cat. III; width III</li> </ul>  |
| Chassis       | <ul style="list-style-type: none"> <li>Double chassis fixed 150 x150</li> <li>3 working width available</li> <li>=&gt; frame 1 tine = working width 1.0 m approx.</li> <li>=&gt; frame 2 tines = working width 2.2 m approx.</li> <li>=&gt; frame 3 tines = working width 2.7 m approx.</li> </ul>  |
| Tines         | <ul style="list-style-type: none"> <li>Hydraulic non-stop safety device, Ø 100 mm rams, accumulator 3.5 l set at 100 bars</li> <li>Steel straight tines, thickness 30 mm, interchangeable points 80 x 30, 2 dimensions available : <ul style="list-style-type: none"> <li>=&gt; under frame clearance 800 mm = working depth 65 cm</li> <li>=&gt; under frame clearance 950 mm = working depth 80 cm</li> </ul> </li> </ul> |

A large choice of options is available to improve machine's job.

Grégoire-Besson authorized dealers know area and working conditions. They may give information according to technical choices and latest equipments evolutions.

Grégoire-Besson is also represented on farm equipment shows.

## 3.3. DIMENSIONS AND WEIGHTS

| Number of tines | Working width | Transport width | Over all length | Over all height        | Approx. weight | Required HP |
|-----------------|---------------|-----------------|-----------------|------------------------|----------------|-------------|
| 1               | 1.00 m        | 1.50 m          | 1.60 m          | 1.65 m<br>"short" tine | 375 kg         | 75 HP       |
| 2               | 2.20 m        | 2.70 m          | 1.60 m          |                        | 900 kg         | 135 HP      |
| 3               | 2.70 m        | 2.70 m          | 1.60 m          |                        | 1 000 kg       | 165 HP      |
| 1               | 1.00 m        | 1.50 m          | 1.60 m          | 1.80 m<br>"long" tine  | 400 kg         | 90 HP       |
| 2               | 2.20 m        | 2.70 m          | 1.60 m          |                        | 950 kg         | 150 HP      |
| 3               | 2.70 m        | 2.70 m          | 1.60 m          |                        | 1 050 kg       | 180 HP      |

Dimensions and weights are indicative and subject to variations according to equipments and options.

Note : after use, ground or residue accumulations may increase machine's weight.

## 3.4. LIGHT AND SIGNS KITS



Light and signs kits are available for all Grégoire-Besson equipments. Contact an authorized dealer.

Note: it is the operator's responsibility to comply with local current applicable law before any transport on public road.

## 4. PREPARING THE TRACTOR

Follow recommendations given in the safety section of this manual. They are not restrictive.

### 4.1. TRACTOR WHEELS

#### 4.2.1. Tractor tyres

Check tractor tyres general state and pressure. Pressure should be the same on both sides of the tractor for a nice drivability in the field and on the road.



**IMPORTANT** : inflate tyres following manufacturer's recommendations.

#### 4.2.2. Distance between tractor tyres

Generally, using a large tillage equipment, the wider is the distance between tyres, the better is the drivability.

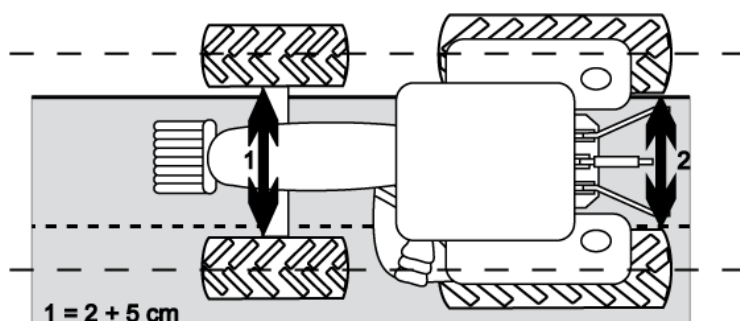

To be able to steer the tractor, the middle of the front axle shall be lined up with the middle of the rear axle.

In sloping fields, a large distance will provide good stability.

### 4.2. FRONT END WEIGHTING

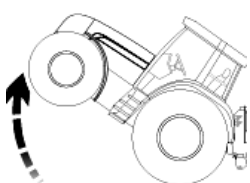

Wheels weights (front and rear) and front end weights may be required to avoid excessive slippage and to increase stability in rough and sloppy grounds.

Weights shall not be added once all slippage is eliminated. Refer to tractor operator's manual and to tractor's dealer. Follow tyre manufacturer's recommendations.

### 4.3. POSITIONING STABILIZERS

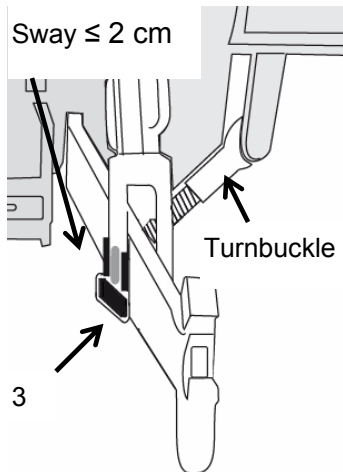

To hitch any tillage equipment on lower link arms, stabilizers shall be set so that arms have minimum lateral sway ( $\leq 2$  cm) and are centred with tractor traction line. This will both prevent from any risk of shock during field operation or road transport and keep machine lined up behind tractor at work.

**Note** : it is easier to adjust and / or service stabilizers bolts and threads before hitching the machine.

Horizontal lift links pins (3) shall be in fixed position to avoid any loose and / or damageable shock.

### 4.4. LIFT LINKS LENGTH

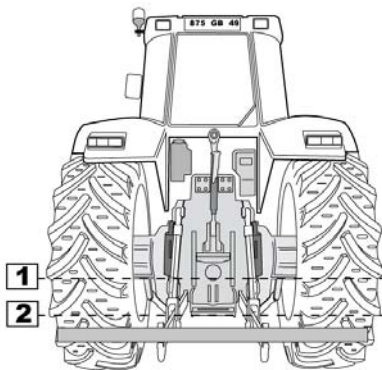

Lift link arms length determines tractor hitch levelling and lift cylinder position at working depth.

- Set lift links length so that tractor hitch is level (refer to picture).
- Set lift links length to have at least 30 mm clearance on lift cylinder rod when machine is working at desired depth. This will give adjustment possibilities for front gang depth from tractor's cab and allow efficient tractor draft control

### 4.5. TOP LINK

Before attaching the machine, make sure that thread length is the same on both sides of top link. Refer to picture, A shall equal B. Top link length will be adjusted in the field.

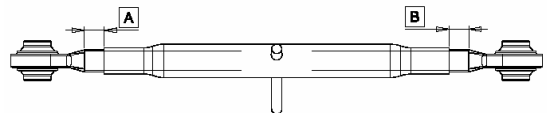

**NOTE** : an excess of grease inside top link tube may make it impossible to shorten. Remove grease fitting to let grease free to go out.

**IMPORTANT** : connection between machine and top link shall be done through a tie rod and never through an automatic hook.

- Automatic hooks sizes and designs change according to models and manufacturers and may cause interference with machine hitch in particular conditions.
- Spring shutter may block hitch ball which may wear or break. This is particularly true for hitches cat III : pin diameter is larger giving less quantity of matter for the ball becoming less strong.



Example of tie rod **CORRECT**

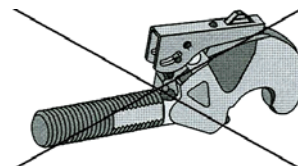

Example of automatic hook **DO NOT USE**

Do not hesitate to contact an authorized Grégoire-Besson dealer for any further information.

## 5. ATTACHING AND DETACHING

Follow recommendations given in the safety section of this manual. They are not restrictive.

**IMPORTANT** : always make sure that hitching never leads to :

- overload : respect maximum admissible hitch load,
- unbalance: load tractor front end if necessary. Refer to point 4.2.

### 5.1. ATTACHING MACHINE TO TRACTOR

Before any manoeuvre, check for diameter and length compatibility between hitch pins and tractor tie rods.

#### **5.1.1. Tractor equipped with tie rods lower links**

- Remove safety bolts and hitch pins.
- Back up tractor to line up tie rods and machine hitch holes.
- Install pins and secure them with their safety clips.
- If holes are difficult to line up : extend telescopic arms as indicated in tractor operator's manual. Once hitch pins are inserted and secured with their safety clips, slowly back up tractor to lock back lift arms. Check for lift arms locking.
- Hitch top link.

#### **5.1.2. Tractor equipped with automatic hooks lower links**

- Remove safety bolts and hitch pins.
- Remove balls from tractor lift link automatic hooks.
- Install balls on pins through lower machine hitching holes. Secure with safety bolts.
- Slowly back up tractor till automatic hooks are lined up underneath hitch balls.
- Raise tractor hitch about 5 cm above ground surface till automatic hooks are locked.
- Check for automatic hooks latch handles good locking.
- Hitch top link.



**IMPORTANT** : make sure to have enough clearance between machine yoke hitch and tractor lower lift links to avoid any possibility of contact from working to raised position. A second verification shall be done once machine is in the field in truth working conditions.

### **5.1.3. Hitching top link**

Connexion between top link and machine has to be done through a tie rod (refer to section 4.5.).

Once tractor lift links are correctly hooked up, check top link general state and compatibility with tie rod. Then attach top link in upper yoke hitch.

Raise machine to the maximum and make sure there are no interference with tractor. Final top link adjustments (length and position) will be made in the field.

Do not forget to install safety clip back.



**IMPORTANT** : make sure to have enough clearance between machine yoke hitch and top link to avoid any contact from working to raised position. A second verification shall be done once machine is in the field in truth working conditions.

Raise the machine and put stand in up position = working position.

Connect hydraulic hose for non stop hydraulic safety device.

## **5.2. DETACHING THE MACHINE**

Before detaching, make sure that ground is flat and firm enough to support the machine. Use safety blocks to support machine components and / or parking stand if necessary.



**DANGER** : do not let any part of your body underneath the machine when lowering it to the ground.  
Crushing may lead to death.

Proceed in the logical attaching opposite way :

- 1) Put stands in low position = parking position
- 2) Completely lower the machine to the ground,
- 3) Remove pressure and disconnect hydraulic line
- 4) Detach top link and lower lift links.

Always operate with care.

## 6. HYDRAULIC CONNEXIONS

Follow recommendations given in the safety section of this manual. They are not restrictive.

### 6.1. REQUIRED HYDRAULIC REMOTES

- 1 SA remote for hydraulic Non-Stop safety device.

### 6.2. HYDRAULIC CONNECTIONS

- Always wipe hydraulic couplers with a clean rag on both tractor and machine sides before connecting circuits.
- Always check for machine hydraulic connectors and tractor remotes compatibility. In case of incompatibility contact an authorized Grégoire-Besson dealer.
- Logically connect hydraulic lines for the user :
  - ⇒ Put most frequently used functions on closest lever
  - ⇒ Watch for the way hydraulic flow is delivered : pull the lever to put machine in transport position (raise up / fold), push it to put machine in working position (lower / unfold).
- Check for hydraulic hoses length : too short they may break during sharp turns, too long they may interfere with tractor lift arms or tyres. In case of any problem, contact an authorized Grégoire-Besson dealer.

### 6.3. HYDRAULIC PRESSURE IN NON-STOP SAFETY DEVICE

In regular conditions, pressure in hydraulic circuit shall be set from **110 to 150 bars** which corresponds to the green area on the pressure gauge. **Always stay in this window.**

Adjustment procedure :

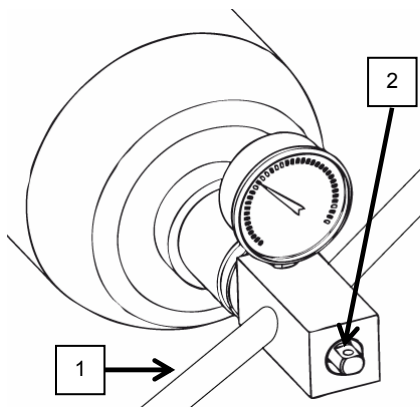

- Correctly connect hydraulic hose (1) to the tractor.
- Open valve (2) situated on the front of the machine.
- To **increase safety device resistance**, increase hydraulic pressure in the system **adding oil**.
- To **decrease safety device resistance**, decrease hydraulic pressure in the system **removing oil**.
- Once desired pressure is reached, shut valve (2). Then hydraulic hose (1) may be disconnected.

Clever way for an operator alone in the field :

- Connect hydraulic hose (1), open valve (2) and add more pressure than required in the circuit. Shut valve (2).
- In tractor's cab, put hydraulic control lever on "Float position".
- Slightly open valve (2) so that oil slowly goes back to tractor.
- Once desired pressure is reached, close valve (2). Then hydraulic hose (1) may be disconnected.



## 7. TRANSPORTING

Follow recommendations given in the safety section of this manual. They are not restrictive.

### 7.1. CHANGING TO TRANSPORT POSITION

Before driving on a public road with the machine, put it in transport position :

- **Attach top link in a fixed hole.**
- **Raise machine to the maximum.**
- Lower the machine to lower gravity centre if necessary. Do not lower too much to avoid any contact with the ground.
- **In the cab lock all control levers** (hydraulic remotes, hitch, ... ), to prevent any unforeseen movement and potential accident.
- **Install all lights, reflectors and signs required by current applicable law.**

### 7.2. DRIVING ON PUBLIC ROAD

Before driving on a public road :

- **Be sure all signs, reflectors and lights required by local current law are in place, clean and visible to traffic.**
- Make sure there are no interferences between tractor and machine.
- Adopt a gentle attitude towards other public road users.

On public road, comply with local applicable laws :

- Tractor required for road transport shall equal the size and the horse power rating of the tractor used to work in the field.
- Do not drive over 25 km/h (= 15 mph).
- Drive at a reasonable speed to maintain complete control of both tractor and machine.
- Reduce speed on corners and on rough grounds.
- Do not drive down a hill faster than it could be possible to drive it up.
- Do not apply the tractor brakes to attempt a sharp turn.
- Always check wheel studs tightness before driving on a public road. They may get loose because of vibrations.
- Respect authorized maximum size for transport load (width, weight, length). For over sized loads, comply with current law taking all necessary precautions (signs, lights, escort, authorizations, ... ).
- Respect the maximum wheel axle load and the maximum total driving load. Make sure front axle carries at least 20% of tractor's tare. Use front end weights if necessary.

**ATTENTION** : driving on public roads, operator is responsible for both tractor and equipment. He has to comply with current applicable law (getting in conformity with it and following its evolutions).

## 8. FIELD ADJUSTMENT

Follow recommendations given in the safety section of this manual. They are not restrictive.

### 8.1. FIELD UTILIZATION

To reach the best result, use machine at a reasonable speed, with a slight angle towards previous crop seeding line (15° to 30°). This will allow :

- To avoid excessive track compaction,
- To improve trash flow and repartition,
- To leave an aerated and levelled ground surface.

Always lift up machine before manoeuvring or turning on headlands.

Never attempt a sharp turn with the machine in the ground.

Reduce speed before manoeuvring or crossing obstacles (ditch, ridge, rocky spots, ... ).

### 8.2. ADJUSTING THE MACHINE

#### 8.2.1. Depth control and front to rear levelling

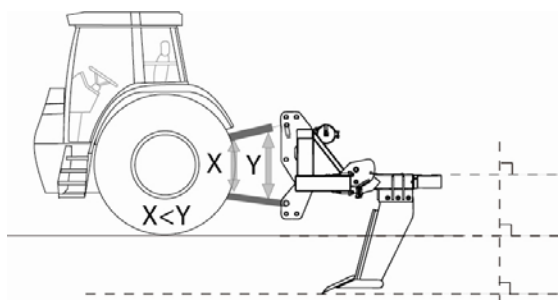

Top link shall be positioned in fixed hole.

To have a constant working depth, set tractor hydraulic lift on control position or on minimum draft control (10% to 20% max).

- **Working depth** is set by height of **tractor hydraulic lift**.
- **Top link length** shall be adjusted so that working at desired depth **machine main frame runs level**.
- **Top link shall always be positioned higher on machine side than on tractor side.** This will allow a good weight transfer on front axle. Refer to picture,  $X < Y$ .

Note : when machine works at desired depth, take a few meters back to check its good levelling.

#### 8.2.2. Side to side levelling

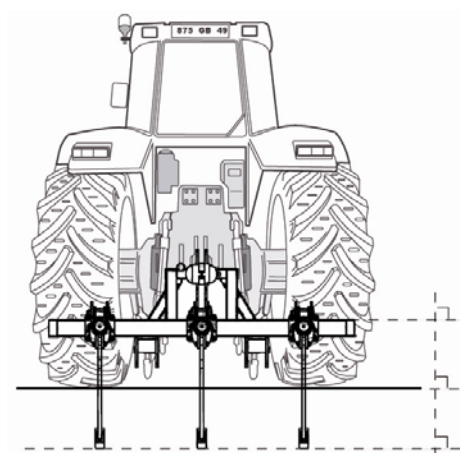

In working conditions, machine shall run level side to side (= from left to right), main frame strictly parallel to the ground.

**It happens most of the time when tractor's preparation has been correctly done** (same tyre pressure on both sides, tractor hitch levelled, stabilization system positioned ...).

Note : when machine works at desired depth, take a few meters back to check its good levelling.

## 9. MAINTENANCE

Follow recommendations given in the safety section of this manual. They are not restrictive.

### 9.1. GENERAL INSTRUCTIONS



**Operator and owner are responsible for good machine maintenance.**



Inspect machine before and after each use. Repairs and service have to be done immediately so that they are not forgotten. Always leave the machine in a good state.

Cleaning the machine facilitates inspection. Check general state of machine, weldings, wheels studs, tyres, ...

Be careful with hydraulic lines : frictions may lead to excessive wearing and lines may leak. Never search a leak with your hands. Immediately replace any defective component. Spare components shall have the same characteristics.

Parts working in the ground may be sharpened and cause severe injury. Take particular care and use heavy leather gloves to remove them.

Never attempt any intervention on the machine while tractor engine is running.

Always properly secure all components before starting any maintenance operation underneath the machine.

Before using the machine for the first time, check all bolts tightness. Verify after 50 working hours and then at the beginning of each season. Pay special daily attention on wearing parts bolts and nuts tightness in rocky or dry conditions (lots of vibrations).

Wrong waste management is a danger for environment : collect waste oil, paint removers, accumulators, worn tyres ... Bring them back to a distributor or to an authorized collector. Do not let them in the nature.

### 9.2. LUBRICATION

A good lubrication of all moving parts will both allow the machine to work fine and insure its long-lasting.

Grease fittings are installed on all pivot points. Grease both lubricates moving parts and chases away abrasive dust or water that could come into pivot points.

Use quality grease, type Unil – Opal MS02 or equivalent.

Always wipe grease fittings with a clean rag before introducing grease. Do not hesitate to change any worn or broken grease fitting. Check for good grease course.

Remove all grease accumulation around grease fittings or moving parts.

Refer to grease fittings placement and frequency on the following drawing. Hard or intense conditions would require more.

**The best is to grease regularly with regular quantity. Do not over grease.**

| Grease fitting placement              | Frequency |
|---------------------------------------|-----------|
| Auto reset safety device pivot points | 50 h      |

## 9.3. SPARE PARTS

Genuine Grégoire-Besson parts have been specially designed and developed. Only the use of these parts will ensure proper fit, longevity and field quality work of the machine.



Using any other spare part than certified from Grégoire-Besson will void warranty.

Changing wearing parts too late may be source of poor quality work (penetration troubles, poor mixing ...) and may damage structure parts.

## 9.4. STORAGE SAFETY

- Before detaching the machine for storage, make sure ground is clean, flat and firm enough.
- Use parking stand and all other locking devices to prevent from any unforeseen movement during detachment or later on.
- Always store machine in working position (= unfolded).
- Block machine wheels to avoid any unforeseen movement.
- During storage, wheels shall not carry any weight.
- NEVER detach machine in raised position.
- Remove pressure from hydraulic circuit (engine shut off, shake hydraulic control lever in the cab).
- Store machine away from human activity.
- Store machine in a dry and dust free area (shed). Protect ram rods that cannot be retracted from rust using grease or oil.

**CAUTION** : never let children play around farm equipment.

# QUICKLY STARTING - SUBSOILER

Take all precautionary measures. Respect safety recommendations.

## PREPARING THE TRACTOR

1. **Check tyre pressure**  
It should be the same on both sides on each axle.  
Always follow tyre manufacturer recommendations.
2. **Adjust tractor hitch levelling**  
Set lift links length for tractor hitch to be perfectly level with the ground.  
Arms shall be long enough so that working at desired depth there is still 30 mm chrome visible on lift ram.
3. **Adjust lift links sway**  
Lateral sway minimum ( $\leq 2$  cm)
4. **Check top link**  
Connexion between top link and machine must be done through a tie rod and not through an automatic hook.

## HITCHING

5. **Attach lower link arms and top link**
6. **Make sure there are no interferences between machine and tractor from raised position to working position**  
Machine shall never come in contact with tractor.  
There should be no contact between tractor lift links and machine yoke hitch.
7. **Connect hydraulic line and set pressure in safety device circuit**  
Open set screw on accumulator, set pressure between 110 and 150 bars, then close shut set screw off.

## FIELD ADJUSTMENT

8. **Machine shall be parallel with the ground at desired depth and speed**  
Side to side levelling      tractor hydraulic lift arms length  
Front to rear levelling    tractor hydraulic lift height and top link length and position (always higher on machine side)

## MAINTENANCE

9. **Follow recommendations given in this manual according to lubrication and maintenance of the machine**

**GRÉGOIRE**  **BESSON**

**49230 MONTFAUCON-MONTIGNÉ-SUR-MOINE  
FRANCE**

**TÉL. (+33) (0)2 41 64 72 67**

**FAX (+33) (0)2 41 64 67 73**

**GRÉGOIRE-BESSON UK**

Bourne Road, Carlby - STAMFORD LINCS PE9 4 NG – ENGLAND  
phone (44) 01 778 590 223 - Fax (44) 01 778 590 645

**GRÉGOIRE-BESSON CANADA INC**

4480, Rue Martineau - ST-HYACINTHE (P. Québec) - CANADA J2R 1V1  
TÉL. (1) 450 799 56 15 - FAX (1) 450 799 56 29

**GRÉGOIRE-BESSON POLSKA**

Ul. Obornicka 1a - PL - 64 600 OBORNIKI - Polska  
TEL/FAX : (061) 29 77 530  
gbesson@poczta.onet.pl  
Ruda 12 - PL - 64610 ROGOZNO – TÉL / FAX (48) (67) 261 97 79

**ООО «ГРЕГУАР-БЕССОН ВОСТОК»**

Россия 308018 г. Белгород,  
ул. Корочанская, 132а  
Тел/факс: +7(4722) 58 70 36, 58 70 35  
E-mail: info@gbvostok.ru

法国格力格尔 - 贝松公司北京代表处  
北京市朝阳区延静里中街3号长信大厦220室  
邮编：100025

**WEB** : [www.gregoire-besson.fr](http://www.gregoire-besson.fr) **E.MAIL** : [Contactfr@gregoirebesson.fr](mailto:Contactfr@gregoirebesson.fr)